

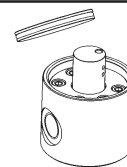

Spray Head FH11 NE-16S for Hangar



Stock code C33010 PRELIMINARY

28 Jul 2003

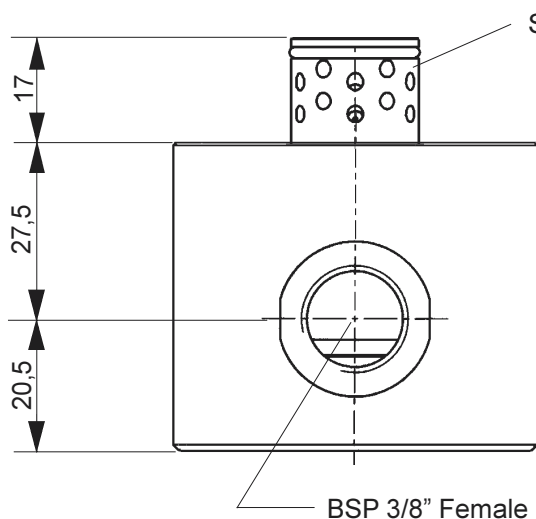

When the system is activated, the spray head is hydraulically ejected from the inserted stand-by position, simultaneously throwing away the protection plate.

Covered Spray Head in stand-by position

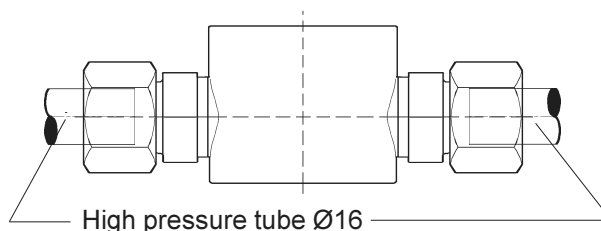
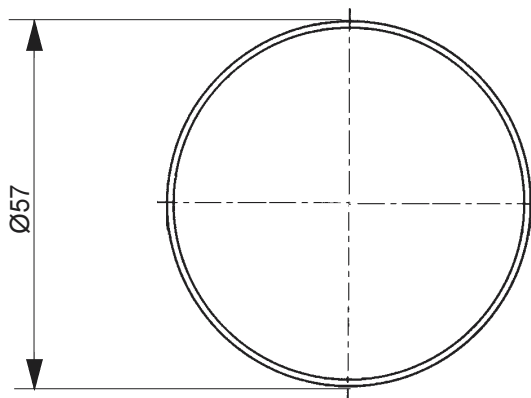
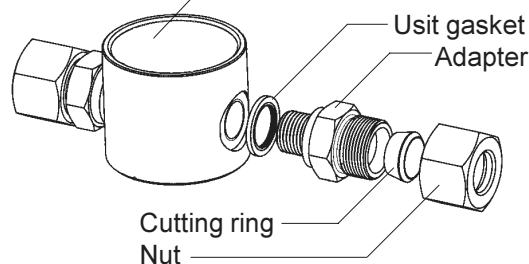

General	Body material	Brass
	Mass	
	K-factor	2,1 lpm/bar ^{0.5}
Installation	Location	In the floor
	Projection	Vertical, upwards
	Max. spacing	2,5 m
	Installation type	Installation submerged in the floor concrete below the floor level.
Typical application	Floor mounted system in hangars to extinguish fire under the aircraft wing level.	